



Marking and Application Guide

ALTERNATIVE ENERGY EQUIPMENT AND SYSTEMS

JANUARY 2012

PREFACE

Interest in the use of alternative energy in the form of renewable energy has increased substantially because of the potential to provide increased reliability and lower cost of power delivery to the customer, particularly with customer-site generation. There are also substantial environmental benefits in reduced or no emissions as compared with traditional technologies.

The new means for generation, storage and transmission of energy present exciting possibilities but raise many questions about safety and reliability, questions that must be answered to ensure public acceptance. For example, the integration of new generation and storage technologies with existing systems need to provide safe and reliable service during peak and off peak demand.

UL is committed to the advancement of safe, renewable and sustainable energy through doing the necessary research, testing and development of standards to help society make a smooth and safe transition to alternative energy.

The equipment and systems used for alternative energy are required to comply with numerous electrical, fire, mechanical, plumbing, and building-related codes and installation requirements. These different codes require compliance with different standards and installation requirements.

UL has developed this guide for use by code and inspection authorities, electric utilities, contractors, installers, users, system designers, and other interested parties to aid in understanding the basic components of alternative energy systems and the applicable codes and standards in order to facilitate a reasonably safe and code-compliant installation.

UL Marking and Application Guides are updated as necessary due to new product development, changes in the codes, or the need for clarification. To confirm the current status of any UL Marking Guide, please consult the Code Authorities page of the UL Web site at www.ul.com/codeauthorities.

Your comments or suggestions are welcome and appreciated. They should be sent to:

Regulatory Services Department
UL
333 Pfingsten Road
Northbrook, IL 60062
ulregulatoryservices@us.ul.com
800-595-9844

TABLE OF CONTENTS

Title	Page
INTRODUCTION	2
1 - ALTERNATIVE ENERGY EQUIPMENT AND SYSTEMS	5
Inverters and Converters	
Distributed Resource Power Systems	
2 - PHOTOVOLTAIC SYSTEMS	6
Modules and Panels	
PV Accessory Equipment	
PV Wire	
3 - THERMAL SOLAR SYSTEMS	13
Solar collectors	
Electrical controllers	
Energy transfer units	
Thermal storage units	
Solar water heaters	
4 - FUEL CELLS AND HYDROGEN GENERATORS.....	14
Stationary fuel cell systems	
Handheld fuel cells	
Industrial truck fuel cells	
5 - ENGINE GENERATORS AND MICROTURBINES	15
Stationary Engine Generators	
Portable Engine Generators	
Engine generator accessories	
6 - WIND TURBINE GENERATING SYSTEMS	16
Large and small wind turbine generating systems	
Safety-related control systems	
Inverters/converters	
Wind turbine tray cable	
APPENDIX A: UL Alternative Energy Product Categories	18
APPENDIX B: Alternative Energy Codes and Standards	21

INTRODUCTION

USE OF THIS GUIDE

This guide is intended to assist regulatory authorities, designers, and installers in determining the suitability of specific alternative energy equipment in a particular installation and use, and to address concerns related to fire, shock, plumbing, gas, and/or mechanical hazards and performance reliability.

Products are Listed or Classified by UL under an appropriate product category. A four-letter code (shown in parenthesis) following every category title in this guide is the UL product category code designation. A list of alternative energy equipment product categories evaluated by UL, along with the applicable standard(s), can be found in Appendix A.

Each UL product category code provides a direct link to the Guide Information for the product category. The Guide Information includes the scope of the products covered, information relating to limitations or special conditions applying to the product, the requirements used for the investigation of the products, installation and use information, and information on product markings and the UL Mark to be used on the product. Guide information is available in the UL White Book and online at www.ul.com/database.

The product markings identified in this guide do not include every possible marking that could be provided either on a product or in its installation or operation instructions. The purpose of these markings is to provide you with an indication of the type of text and location of markings that address features that may be critical in determining if a product is certified and / or if it is installed correctly. Refer to the specific Guide Information for the product category for additional marking information.

The numbering for code sections used in this document may change as the specific code is updated. A list of model codes and standards applicable for each product can be found in Appendix B.

Additional information can be found at www.ul.com/renewable.

INFORMATION ON LISTING VERSUS CLASSIFICATION

Most codes and regulations require the certification of this equipment to applicable safety-related standards. They also may require this equipment to be certified to energy performance standards as well. Products that are certified to safety-related standards have been evaluated with regard to all reasonably foreseeable safety-related hazards, including fire, electrical shock and mechanical hazards. Such products are termed “UL Certified” or “UL Listed.” Products that are certified to a limited range of hazards, or for use under specific conditions are termed “UL Classified”.

It is important to distinguish the difference between “UL Certified” or “UL Listed” and “UL Classified” and the relation these terms have with the term “listed,” as used in various codes. The term “listed” in the codes generally indicates that the product is required to be evaluated in accordance with the appropriate standard(s) by an independent third party certification organization such as UL. The term “listed” in the codes should not be confused with the term “UL Listed,” as explained above. It is important to recognize that not all certification agencies make this distinction in their certification services.

INFORMATION ON UL MARKS

There are several types of UL Marks that can be found on alternative energy equipment. General information on each of these Marks is provided below. Each has its own specific meaning and significance. The only way to determine if a product has been certified by UL is to look for the UL Mark on the product itself.

The UL Mark on a product means that UL has tested and evaluated representative samples of that product and determined that they meet the requirements in the applicable standard(s). Under a variety of UL programs, certified products are periodically checked by UL at the manufacturing facility to determine that they continue to comply with the standard(s).

The UL Marks may only be used on, or in connection with products certified by UL, and under the terms of a written agreement between the manufacturer and UL.

UL Listing Mark

This is one of the most common UL Marks. If a product carries this Mark, it means UL found that representative samples of this product met UL's *safety* requirements. These requirements are primarily based on UL's own published Standards for Safety, or other recognized third party standards. The UL Listed Mark includes the UL symbol, the word "Listed," the product or category name, and a control number assigned by UL.



UL Classification Mark

This Mark appears on representative samples of products that UL has evaluated but only with respect to specific properties, a limited range of hazards, or suitability for use under limited or special conditions. The UL Classified Mark includes the UL symbol, the word "Classified," a statement of the scope of evaluation, the product or category name, and a control number assigned by UL.



PV Global Approval Mark (GAP)

Although this certification may be issued in conjunction with a safety certification, this certification is not considered a safety certification. This certification is for design qualification and type approval of PV modules and panels in accordance with IEC 61215 and IEC 61646.

This Mark is for photovoltaic (PV) products that have only been evaluated for an extension of the CB Full Certification Scheme (CB-FCS) based on authorization from the International Electrotechnical Commission's System for Conformity Testing and Certification of Electrical Equipment and Components (IECEE). In addition to the CB Certification under the CB-FCS program, ISO 9000 registration and an ongoing product follow-up surveillance program are required. UL is a member of the IECEE, and is a National Certification Body (NCB).

For more information, refer to the Guide Information for “Photovoltaic Modules and Panels – PV GAP Mark” (QIMY) or “Photovoltaic Lanterns – PV GAP Mark (QIMV).



PV GAP QUALITY MARK

FIELD EVALUATIONS

You may encounter situations in which you are unable to determine if a product has been listed by a third-party organization. Or in other situations you might encounter a product bearing a listing label that may have been modified in the field, and now you question whether or not the product still complies with the applicable standard. UL offers a field evaluation service that provides data to assist you in making your decision whether to accept the product and/or approve the installation. Anyone directly involved with a product – including manufacturers, owners, contractors, and regulatory authorities – can request a Field Evaluation. Detailed information for this program can be found on UL’s Web site at www.ul.com/field.

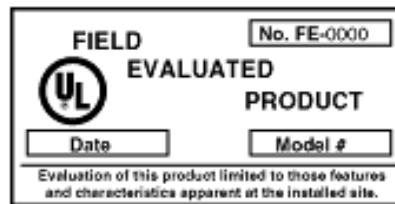

1. ALTERNATIVE ENERGY EQUIPMENT AND SYSTEMS

Alternative energy is either distributed or localized generation. The power source of alternate energy equipment and systems is one of the following or a hybrid combination – photovoltaic panels, wind turbines, engine generators, microturbines, or fuel cells. There are three system types:

- Interactive – operates in parallel with and may deliver power to an electrical production and distribution network
- Hybrid – comprised of multiple power sources
- Stand alone – supplies power independently of an electrical production and distribution network

The main concerns regarding the installation and use of distributed or localized generation are safety, power quality, harmonic distortion, and “islanding”. “Islanding” is when the distributed generation equipment continues to feed power to the grid when the utility source has been disconnected, resulting in sourcing an “island” or part of the grid. Installation requirements for interconnection with electrical power production sources are covered by NEC Article 705.

Inverters and converters (QIKH)

An inverter provides AC power at a useable voltage and frequency for connection to the utilities' electric power grid or to provide power for off-grid loads. In general, it converts the output of photovoltaic panels, fuel cells, wind turbines, and microturbines to an appropriate AC voltage and frequency for direct domestic and industrial use. More complex units can also supply power with the proper characteristics to the utility grid.

A converter is a device that accepts AC or DC power and converts it to another form of AC or DC power for direct utilization by a load or accumulation in an energy storage system.

Tests are conducted in accordance with the requirements of UL 1741. The extent of the test work depends on whether the product is a stand-alone unit or intended for interconnection with the local utility. The standard addresses the risks of fire and shock to service personnel and the general public. Inverters and converters for RV and land vehicles use (QPPY) and marine use (QPQL) are investigated using ANSI/UL 458.

There are three classes of inverters:

- Utility interactive – operate in parallel with, or backfeed power to the utility grid to supply common loads
- Stand alone – supply power to loads independent of the utility grid
- Multimode – can operate in both utility interactive and stand-alone modes in case of utility failure.

For inverters identified as utility interactive, the standard addresses power quality, synchronization of power back into the grid, and anti-islanding protection. The utility-interactive inverters prevent the exportation of power after a utility outage in order to mitigate potential shock hazards to utility line crews, current contribution to the utility fault, potential problems in re-energizing the power lines, and damage to equipment if the power line is re-energized out of sync with the inverter.

Markings on inverters include the following:

- The name of the manufacturer and the model number
- Range of input operating voltage
- Maximum input current (AC or DC)
- Output power factor rating
- Operating voltage range (AC)
- Operating frequency range or single frequency
- Nominal output voltage (AC)
- Normal output frequency
- Maximum continuous output current (AC)
- Maximum continuous output power (AC)
- Maximum ambient temperature rating (if evaluated for higher than 25°C / 77° F)
- Installation environment (e.g. “indoor use only”)
- “Utility-Interactive” or “Interconnection System Equipment” if appropriate

The model ratings for each inverter are posted on UL’s Online Certification Directory. Some inverters need to be installed and operated with an external transformer and/or overcurrent protection (input or output), as specified in the markings and installation instructions. The required external overcurrent protection is to be sized at 125% of the inverter’s output current rating unless otherwise specified.

Installation instructions for inverters identify the wire size, wire type, wire rating, location limitations of the product, clearances, torque values for the wire terminals, and the electrical ratings.

Distributed Resource Power Systems (QIJL)

Distributed resource power systems, consisting of combinations of batteries, energy storage devices, utility interconnection systems equipment, and protective relays, are investigated in accordance with applicable requirements from UL 1703, UL 1741, and ANSI/UL 2200. This combination of equipment is intended to combine, convert, transform or relay energy from one or more ac or dc sources for use in stand-alone and/or utility-interactive power systems. They are factory or field wired assemblies in which the combination has been investigated for operation as a system assembly when installed in accordance with the installation instructions.

Solar Power

There are two types of solar power – photovoltaic and thermal. Photovoltaic converts light directly into electricity using semi-conductor technology. Thermal solar uses the sun’s radiation to heat water for buildings and swimming pools.

2. PHOTOVOLTAIC SYSTEMS

Photovoltaic (PV) technologies use treated crystalline silicon operating as a semiconductor to generate a flow of direct current electricity when exposed to light. PV technologies are evolving, allowing PV use in products such as flexible roofing applications and using other materials such as thin-film polymer.

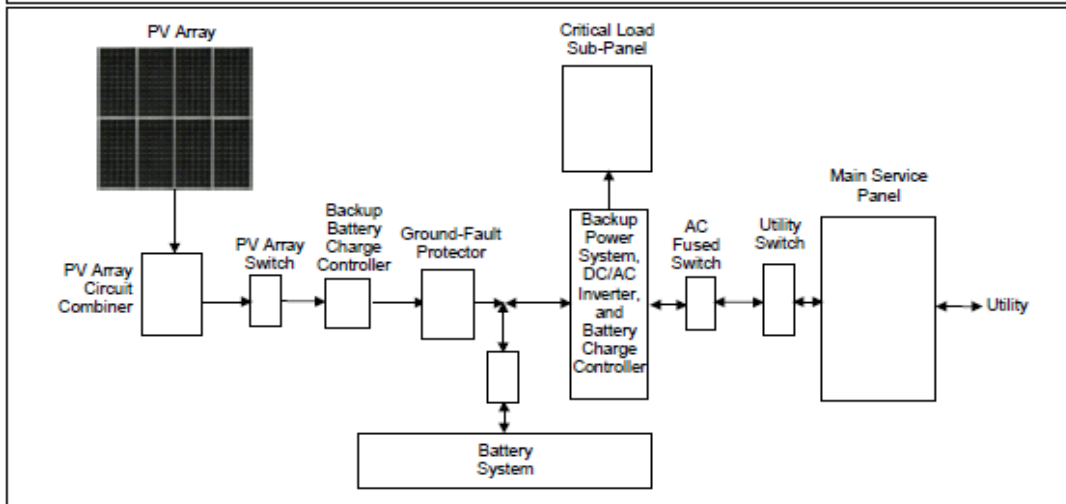
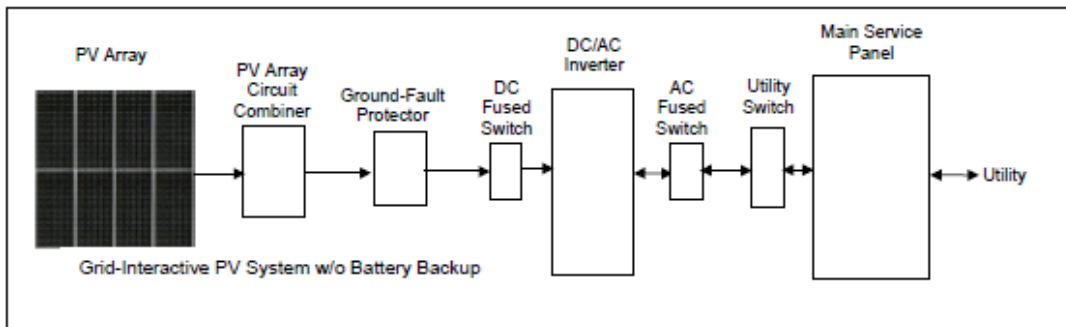
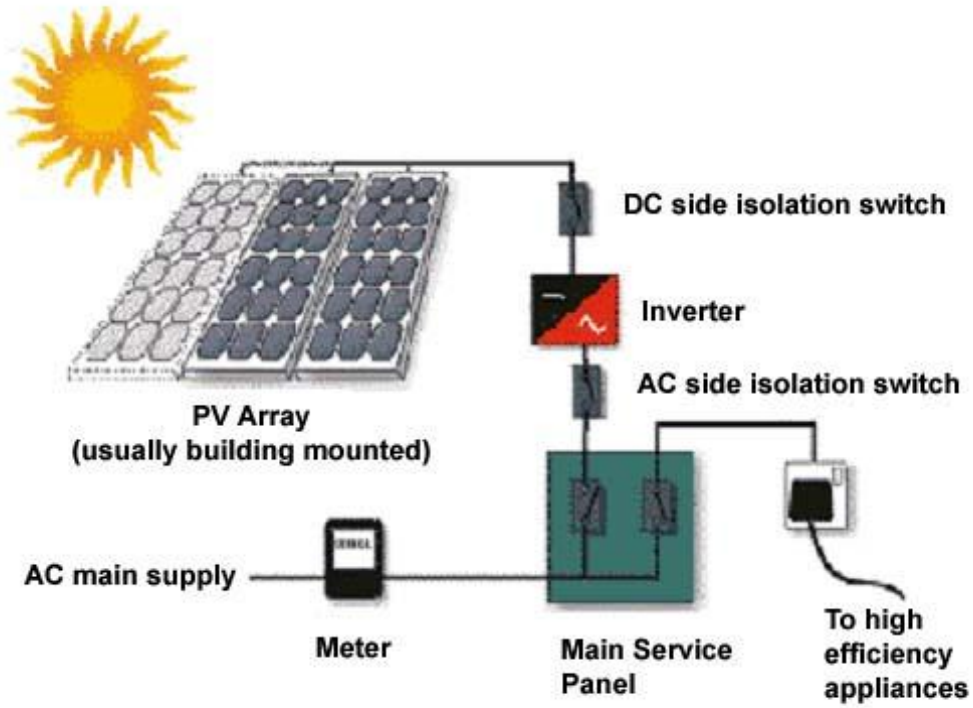

Alternative Energy Equipment and Systems Marking and Application Guide

Photovoltaic (PV) systems convert sunlight directly into electricity, which enables the generation of some or all of the daily electrical energy demand for a building. Utility interactive systems remain connected to the electric utility at all times, so any power needed above what the solar system can produce is simply drawn from the utility. PV systems include mounting systems and wiring systems used to integrate the solar modules into the structural and electrical systems of the building. The wiring systems include disconnects for the dc and ac sides of the inverter, ground-fault protection, combiner boxes, and overcurrent protection for the solar modules. Some inverters include this fusing and combining function within the inverter enclosure. PV systems can also include battery backup or uninterruptible power supply (UPS) capability to operate selected circuits in the building for hours or days during a utility outage.

Product installation concerns for photovoltaic systems include:

- Utility compatibility and interaction
- Environment (e.g. indoor, outdoor, hazardous location)
- Maximum number of modules (effecting voltage/current/short-circuit)
- Fire exposure ratings (effect on roof covering)
- Wind and snow loading
- Mounting and attachment
- Grounding and bonding
- Shading

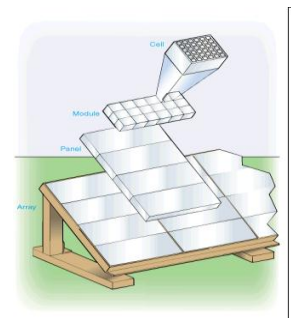

Modules and Panels

A PV module consists of solar cells connected together in the factory. The most common PV module is 5 to 25 ft². PV modules have ratings from 12V to 100V and power ratings from 5w to 400w. Often sets of four or more smaller modules are framed or attached together by struts in what is called a panel. This panel is typically around 20-35 ft² in area. This allows some assembly and wiring functions to be done on the ground in the factory or in the field in accordance with the installation instructions.

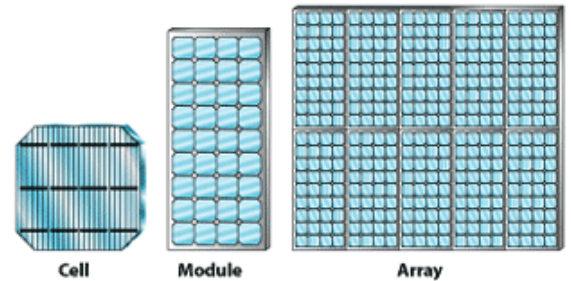

PV panels are "strung" together in series, referred to as a PV array, to increase the voltages from 120Vdc up to 600Vdc. Under normal conditions the current of these strings is usually from 5 to 10 amps. The NEC limits residential PV maximum system voltage to 600Vdc. PV panels can also be connected together in parallel to increase the current.

The construction of the product, the safety performance, materials and the manufacturing process are all assessed in determining the compliance of the module or panel to the requirements of the applicable standards. The product's output wiring system is also investigated for conformance with the conventions of the NEC. The safety performance includes electrical, temperature, mechanical loading, and fire tests.

AC modules (QHYZ) provide single-phase power at 50/60 Hz when exposed to sunlight. An AC module consists of a photovoltaic module and an integral static inverter that changes dc power to ac

power. AC modules may be connected in parallel and are intended for operation interactive with an electric utility supply. They have been evaluated to de-energize their output upon loss of utility power. These modules are rated up to 600 V dc input; 10 kW, 120/240 V ac or less, single-phase output. The basic standards used to investigate these modules are UL 1703 and UL 1741.

PV modules and panels (QIGU) intended to be connected to electrical loads, controllers, or to static inverters that convert the dc power the modules or panels generate to other types of power compatible with the intended loads are investigated using UL 1703. Flat-plate PV modules and panels rebuilt (QIGZ) by the original manufacturer or a third party manufacturer are subject to the same requirements as new flat-plate photovoltaic modules and panels. PV modules and panels for use in hazardous locations (FCJU) are identified with the aforementioned ratings and Class and Division ratings.

Concentrator Photovoltaic (CPV)

Concentrator photovoltaic modules and assemblies (QICP) use lenses and reflectors to concentrate sunlight on photovoltaic cells to increase output power. The installation class for CPV modules and assemblies identifies the intended installation location as either general access areas designated "General," or restricted access areas designated "Restricted." General access units are able to be installed in open areas that may be contacted by the general public. Restricted access units are intended to be installed in areas that prevent general public access, such as a locked and fenced-in area. The basic requirements used to investigate products in this category are contained in UL Subject 8703.

PV modules and panels are intended for mounting on buildings or on ground-supported frames. Roof-mounted modules or panels are investigated for one of three mounting methods: (1) integral to the roof of a building, (2) directly on a building's roof, or (3) on a rack with a space above the roof surface.

When mounted integral to a building's roof the module (also known as BIPVs) serves as the waterproof membrane. Direct-mounted panels are placed upon the building's waterproof membrane, such as roofing shingles. Rack-mounted styles are spaced away from the building's roof membrane. Rack-mounted styles may also be installed separate from buildings. Installation of modules on or integral to a building's roof system may or may not adversely affect the roof-covering materials' resistance to external fire exposure if the module has a lesser or no fire-resistance rating. Roof-covering materials will not be adversely affected when the modules have an equal or greater fire-resistance rating than the roof-covering material.

PV modules or panels are additionally identified as Class A, B or C to denote their Classification for resistance to external fire exposure to correlate with the rating of other roofing materials and systems as required by the International Building Code (IBC) Chapter 15. Rack-mounted modules or panels that have not been identified with respect to their resistance to external fire exposure are marked "Not Fire Rated." Photovoltaic roofing shingles (TFXX) are intended to be applied directly to a combustible deck in accordance with manufacturer's instructions. Roofing systems (TGFU) that are an assembly of several components, including the PV modules and panels, may require special equipment for application and are intended to be installed on a roof deck as specified by the system.

Building-Integrated Photovoltaic (BIPV)

Building-integrated photovoltaic modules and panels (QHZZ) are intended for mounting integrally to the structural or protective surfaces of a building in one of three primary installation methods: (1) to serve as the roof, or as a majority component of the roofing system of a building (TFXX, TGFU), (2) to serve as part of a structural component of a building, such as a curtain-wall, facade, atrium, skylight, etc., or (3) to serve as part of a nonstructural component of a building, such as a curtain-wall, facade, atrium, skylight, etc., which is applied extant to the primary building structure. These modules and panels and their mounting systems (QHZZ) are investigated using UL 1703, and ANSI/UL 790 and UL 997 as appropriate.

PV Markings and Installation Instructions

Markings for PV modules and panels include:

- Electrical ratings - $V_{\text{Open Circuit}}$, $V_{\text{Operating}}$, $V_{\text{Max System}}$, $I_{\text{Short Circuit}}$, I_{Rated} , P_{max}
- Terminal polarity and temperature of output connections
- Maximum series overcurrent device rating
- Minimum acceptable diode bypassing (if needed)
- Fire Rating – “Not Fire Rated” or Class A, B, or C

Grounding and bonding of the panels and modules and racking systems are required to be done in accordance with the manufacturer’s installation instructions, due to concerns of dissimilar metals and exposed terminations.

The installation instructions for the PV modules and panels include:

- Max. System Voltage (to not exceed the inverter)
- Wire sizing
- Maximum series fuse rating (dc rating)
- Electrical Data - V_{oc} , I_{sc} , Temperature, V_{mp} , I_{mp} , P_{max}
- Grounding methods & location
- Clearances to roof for rack-mounted
- Designation of attachment

Model code requirements for photovoltaic systems are found in the National Electrical Code (NEC®) Article 690; International Building Code (IBC) Chapters 15, 16, and 24; and Uniform Solar Energy Code (USEC) Chapter 10.

The standards IEEE 1262, IEC 61215, and IEC 61646 are used for design qualification of modules and panels (QIMY). This is not a safety certification.

PV Accessory Equipment

PV accessory equipment (QIIO) include:

- Actuators
- Blocking diodes
- Conduit boxes

- Connectors
- Controllers (control boxes)
- Communication modules
- Disconnects
- Distribution panels
- Transition boxes

Most systems include a combiner box since most modules require fusing for each module source circuit. Manufacturer's installation instructions for combiner boxes include:

- Wire size
- Terminal Ratings and torque values
- Mounting orientation / Location
- NEMA enclosure rating

A charge controller (QIBP) is a device to control the charging process of energy storage products such as batteries. These devices are necessary to match the output voltage of the DG source with the rated voltage of the battery or other storage medium. They also control the level and rate of charge to prevent damage to the storage medium.

An output controller is a device external to an inverter, converter or utility interactive distributed generation source that performs utility interface functions including over- and under-voltage, over- and under-frequency, synchronization, and anti-islanding protection.

PV panels are inherently limited sources and are not provided with direct output overcurrent protection. They are designed to operate within 20% of the short circuit current. The NEC[®] Section 690.5 requires a means to detect a ground fault in the PV system caused by abuse, wear, cutting, and pinching of the wire. Ground fault detector interrupters (QIIO) interrupt the flow of fault current, and provide an indication of the fault. Inverters and controllers either incorporate these devices or are marked to require these devices to be added in the field.

PV Wire (ZKLA)

A new wire has been specifically designed for interconnection wiring of grounded and ungrounded photovoltaic power systems as described in NEC[®] Section 690.31(A). The Photovoltaic Wire is a single-conductor, insulated and integrally or non-integrally jacketed, sunlight resistant, rated 90, 105, 125 or 150°C dry, and 90°C wet, 600, 1000 or 2000 V. The basic requirements used to investigate the wire is UL Subject 4703. The wire is labeled "Photovoltaic Wire".

Connecting to Panelboards and Switchboards

Panelboards and deadfront switchboards are not Listed to have their busbars tapped unless there are existing holes in the busbars marked with the word "Tap" adjacent to the holes. Other holes in the busbar that are not marked with the word "Tap" are intended for the connection of overcurrent devices, other device's as identified by the product markings and in the installation instructions or other uses identified by the manufacturer. When the electrical equipment Listing does not include product markings or instructions for tapping busbars, this situation should be treated like any other field modification of Listed equipment.

Some Listed power equipment may have installation instructions with specific directions on tapping the busbars. If this is the case, this equipment can be field modified, following those manufacturer's

instructions, in accordance with the National Electrical Code® (NEC) Section 110.3(B). The UL White Book identifies the required markings for field-installed equipment that have been evaluated by UL. For additional information, please see the guide information for panelboards (QEUY) and for dead-front switchboards (WEVZ).

If not addressed in the installation instructions, any modifications must be evaluated by the Code Official according to NEC Section 110.3(A) or by having a UL Field Evaluation conducted. A terminal or provision for a terminal in a panelboard or switchboard which has been evaluated for use as a tap, other than those to be used by the supply utility for voltage metering pick-up, are marked "Tap" in the factory. Drilling or enlarging holes in busbars can increase the current density and reduce current carrying capacity. Some equipment is constructed with fully rated busbars, which have a typical current density of 1000 A per square inch of cross sectional area for copper and 750 A per square inch of cross sectional area for aluminum. However, some equipment uses busbars at a higher current density and have temperature testing conducted to determine compliance with UL's requirements.

Removing busbar material can result in higher operating temperatures, and additional holes can potentially weaken the busbar, which adversely affects the short circuit rating of the equipment required by NEC Section 110.10. Both sufficient wiring space and wire bending space need to be provided for the conductors and the wire connector at the tap connection. In measuring the wiring space, code officials need to consider the possibility of the connectors rotating, which may result in reduction of the spacing between uninsulated live parts of opposite polarity and uninsulated live parts and ground.

Wire connectors (lugs) need to be Listed for the purpose and have the proper ratings for specific application, and the mounting hardware for wire connectors needs to be properly selected and attached with the correct torque. The potential reduction of required spacings from the wire connectors or fasteners to the enclosure or other busbars also needs to be evaluated. In completing the modification, all foreign material such as cutting oil, burrs and metal shavings needs to be removed from the equipment enclosure. Temporarily removed materials such as insulating barriers need to be returned to their original positions and secured. The above are just a few of the concerns and items that must be inspected, checked and reviewed where such modifications are made to this type equipment.

3. THERMAL SOLAR SYSTEMS

Thermal solar systems involve direct utilization of solar energy for space heating, space cooling and/or water heating systems. The basic requirements used to investigate products in these systems are contained in UL Subject 1279.

UL's Solar Energy Systems Equipment product categories are:

- Solar Energy Systems Equipment (UZST)
- Controllers, Electrical, Solar (UZVY)
- Thermal Storage Units, Solar (UZWW)
- Water Heaters, Solar (UZWZ)
- Collectors, Solar (UZUW)
- Energy Transfer Units, Solar (UZWT)
- Radiant Heating Hose (MEKC)

Product installation concerns include:

- Environment (unless evident for outdoors or marked as such, indoor use only)
- Type of storage media or fluid
- Max temperature and pressure ratings
- Roof classification
- Mounting methods

Applicable installation codes and standards are UMC Chapter 15; IMC Chapter 14; IBC Chapters 15, 16, and 26; and USEC. The codes include specific requirements for roof mounting of the collectors, heat transfer fluids, and equipment and materials.

Using solar for thermal heating provides credits in various green building codes and standards, such as Section 704.3.2 of ICC 700.

4. FUEL CELLS AND HYDROGEN GENERATORS

A typical Fuel Cell is an electrochemical device that converts hydrogen into electrical energy and heat. Current technologies are the proton exchange membrane fuel cell (PEMFC), the phosphoric-acid fuel cell (PAFC), the solid oxide fuel cell (SOFC), and the molten carbide fuel cell (MOFC).

The technology is broad and includes a wide variety of applications. Currently, UL evaluates stationary fuel cells used as electric power sources for residential and commercial and backup voltage sources for uninterruptible power supplies for critical computer and telephone applications (IRGZ), portable battery replacement power sources for cell phones and other electronic equipment (IRGU), battery replacement power sources for industrial trucks (IRGQ), Additionally, fuel cells are beginning to be used by the utility companies as a source of supplemental power during periods of peak demand.

A basic summary of a fuel cell power system is that it consists of either a reformer to extract hydrogen from fuel or can be supplied with a direct source of hydrogen, a fuel cell, and power conditioning circuitry which may include an inverter. Applicable codes and standards are NFPA 853, NEC Articles 692 and 705, CSA FC-1, UL Subject 2262, UL Subject 2265A, UL Subject 2265C, ANSI/UL 2267, UL 1741, IFGC Section 633, IMC Section 924, and UMC Chapter 16.

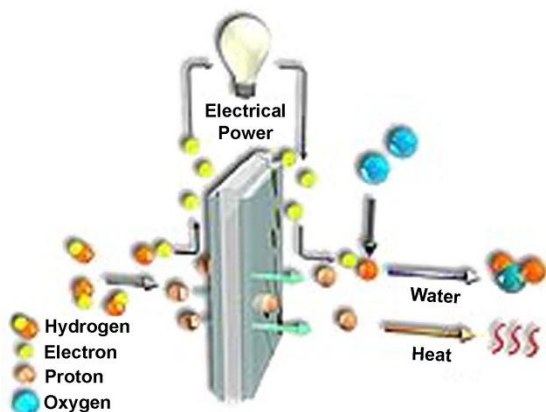

PEM Fuel Cell technology

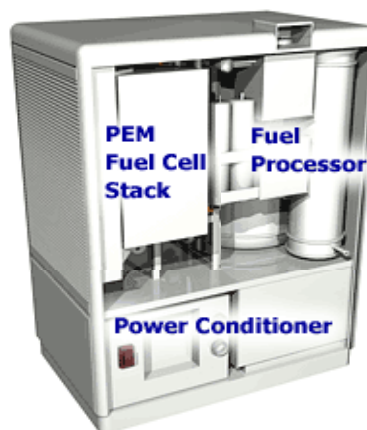

5. ENGINE GENERATORS AND MICROTURBINES

Microturbine and engine generator products are electricity-producing assemblies typically located at or near the point of use. They are typically installed so that back-up (standby or emergency) power is available to the user in the event of a utility grid failure. In some installations, these units can be connected in parallel with the local electric utility power grid and used for peak shaving or excess power can be sold back to the utility. In other applications, microturbines and engine generators are located off the grid in rural and remote areas where they provide the sole source of power (prime or continuous), or they operate in combination with other sources such as photovoltaic or wind turbine installations.

Internal combustion gasoline, natural gas, propane and diesel engines from the automotive and marine industries have been coupled to rotating field alternator and generator devices for many years. In addition, the turbine engines now being coupled to high-speed generators in microturbine applications are from the same family of small jet engines that have been employed in the military and transportation industries for the past 50 years. These systems are considered to employ the most reliable power producing technologies ever used in stand-alone and distributed systems.

Tests for stationary engine generators are conducted in accordance with the requirements of UL 2200, which include an evaluation of fire hazards, electric shock hazards, casualty hazards (including power interruption consequences) and reliability analysis. Additional tests may be conducted based on NFPA 110 and to deal with special situations such as the evaluation to show that abnormal leakage is handled appropriately, or gas component sections of the product are ventilated as designed.

Tests for portable engine generators are conducted in accordance with UL 2201. The electrical evaluation includes control panels, safety control reliability analysis, cycling durability tests, circuit analysis, and system software. The mechanical evaluation includes fuel tanks, venting, and the combustion engine.

Model installation code requirements for engine generators are covered in IFGC Section 616, IMC Section 915, IBC Section 2702, IFC Section 604 NFPA 37, NFPA 99, and NFPA 110.



6. WIND TURBINE GENERATING SYSTEMS

Large and small wind turbine generating systems and assemblies (ZGAA)



Wind turbine generating systems produce electric power from a wind driven generator. Wind turbines consist of blades, hub, generator, drive train, support structure, control, power collection, power distribution and protection systems. Small wind turbine generating systems (ZGEN) are defined as wind turbines with a rotor swept area of 200 m² (16 meters rotor diameter) or less, and an output terminal voltage of 600 Volts or less. Large wind turbine generating systems (ZGEA) are defined as turbines with a rotor swept area larger than 200 m² (16m rotor diameter). Large Wind Turbine Assemblies (ZGBP) and small wind turbine sub-assemblies (ZGZJ), consisting of various electrical hardware components and subassemblies constructed and interconnected in accordance with electrical safety requirements, are used to create a complete wind turbine.

These systems are evaluated for risk of fire and shock, including safety related control system electrical performance and utility grid-interconnect performance for Utility Interactive models. The basic requirements used to evaluate large and small wind turbine generating systems, and large and small wind turbine assemblies, and safety related control systems, is Subject 6140-1, UL's "Outline of Investigation for Wind Turbine Generating Systems".

The electrical equipment systems are intended for installation in accordance with the requirements in NEC® Article 705. Mounting means, support structures, wind turbine blades, and/or rotors are only evaluated to the extent that they include the necessary electrical components to comply with the applicable electrical safety standards. Local wind, snow, and seismic loading, and local soil conditions are unique for each jobsite location, and thus should be evaluated by the local jurisdiction.

Safety Related Control Systems (ZGCP)

Safety Related Control Systems consist of electrical hardware and software which operate to control and protect the wind turbine generating system, and functions up to the electro-mechanical interface of the associated power and control circuits. These systems are for use with specific wind turbine generating systems as defined by each product's UL Classification.

These systems are evaluated to perform specific wind turbine control and protection functions to maintain the overall system within the manufacturer's specified operational limits. These control and protection functions are evaluated with respect to risk of electric shock and fire, and electrical response time. It is intended that the electrical subassemblies that address power transfer control and protection functions evaluated by UL be coordinated with a mechanical and structural evaluation of the wind turbine generating system in accordance with standards such as the IEC

61400 series documents or Germanischer Lloyd WindEnergie GMBH: Guideline for the Certification of Wind Turbines documents.

The Safety Related Controls System, as defined in UL Subject 6140, embodies the “Controls System” and “Protection System” functions defined in IEC 61400 and Germanischer Lloyd WindEnergie GMBH: Guideline for the Certification of Wind Turbines documents, GL-IV.

Inverters and Converters (ZGFA)

Inverters are devices that change DC power to AC power. Converters are devices that accept AC or DC input power and convert it to another form of AC or DC power for direct utilization by a load or accumulation in an energy storage system (batteries, capacitors, etc.).

Both of these devices are classed as Utility Interactive, Stand-alone or Multimode. Utility Interactive devices operate in parallel with the utility grid. Stand-alone devices are intended to operate independent of the utility grid. Multimode devices can operate as both or either Stand-alone (utility independent) or Utility Interactive devices. Each product is marked to identify its class.

Electric utility grid interconnection performance is evaluated to limits defined by the manufacturer for synchronization, overvoltage, undervoltage, overfrequency, underfrequency, clearing times, reconnect time, power factor, DC injection, harmonic distortion, unintentional islanding, power range and low voltage ride-through (if provided).

Inverters and converters may contain energy storage devices and associated charge controllers. Some devices must be installed and operated with an external transformer. Such devices are provided with markings and instructions to indicate the type of transformer required. Some devices may require external input and / or output overcurrent protection, which will be specified in product markings and installation instructions.

Some devices in this category must be installed and operated with an external transformer. Such devices are provided with markings and instructions to indicate the type of transformer required. These products may require external output overcurrent protection, which will be specified in product markings and installation instructions.

The basic requirements used to evaluate inverters and converters is UL Subject 6141, which requires that all converters be evaluated for both normal and abnormal conditions associated with the application (less electric utility “grid” interconnection protection). For electric utility connected converters this includes the evaluation of the unit’s ability to parallel two sources of power, operate during normal utility operating conditions, provide a minimum level of output power quality including DC injection and operate safely during abnormal utility grid conditions defined by the manufacturer’s specified product ratings.

Products that have not been evaluated for electric utility “grid” interconnection protection will be marked to indicate that the electric utility grid interconnection protection functions have not been evaluated and need to be addressed at the end installation with the local utility AHJ per local codes and standards. This will often require the installation of additional electric utility interconnection protection equipment and field-testing per the local utility interconnection requirements.

APPENDIX A

UL ALTERNATIVE ENERGY PRODUCT CATEGORIES

UL does list this type of equipment and continues to develop new product categories to address the safety issues associated with this type of equipment. Below is a list of product categories that UL currently lists to address these types of products. Each product category is tabulated with a UL Category Code. By clicking on the code, you will be linked to the UL Guide Information for the category and any Listings or Classifications under that Product Category in the UL Online Certifications Directory database at www.ul.com/database.

Category Code	Category Name	Standard Used
QHWJ, FCHD	Distributed generation power systems equipment	
QIKH	Static Inverters and Converters for Use in Independent Power Systems	UL 1741
QPPY	Power Converters/Inverters and Power Converter/Inverter Systems	UL 458
FFZS	Power Converters for Use in Electric Land Vehicles	UL Subject 458A
QPQL	Converter and Inverter Systems -- Marine	UL 458
QIIO	Distributed Generation Power Systems Accessory Equipment	UL 1741
QIJL	Distributed Resource Power Systems	UL 1703, UL 1741, and/or UL 2200
BBFX	Batteries for Use in Light Electric Rail and Stationary Applications	UL Subject 1973
	Photovoltaics	
QHYZ	AC Modules	UL 1703 and UL 1741
QIGU	Photovoltaic Modules and Panels	UL 1703, IEEE 1262
QIIA	Photovoltaic Modules and Panels with System Voltage Ratings Over 600 Volts	UL 1703
QIGZ	Remanufactured Photovoltaic Modules and Panels	UL 1703
FCJU	Photovoltaic Modules and Panels for use in Hazardous Locations	UL 1703
QICP	Concentrated Solar Power Equipment	UL Subject 8703
QIHC	Concentrator Photovoltaic Modules and Assemblies Classified in Accordance with IEC 62108 and/or CEI 82-85	IEC 62108, CEI 82-85
QIHS	Photovoltaic Modules and Panels Classified in Accordance with IEC 61646 and/or EN 61646	IEC 61646 and/or EN 61646
QIHZ	Photovoltaic Modules and Panels Classified in Accordance with IEC 61730-1 and 61730-2 and/or EN 61730-1 and 61730-2	IEC 61730-1 and 61730-2 and/or EN 61730-1 and 61730-2
QIHO	Photovoltaic Modules and Panels Classified in Accordance with IEC 61215 and/or EN 61215	IEC 61215 and/or EN 61215
QHZZ, TFXX, TFGU	Building-Integrated Photovoltaic Modules & Panels	UL 1703, UL 790, UL 997

QHZZ	Building-Integrated Photovoltaic Mounting Systems	UL 1703, UL 790, UL 997
QHZZ	Flat-plate, Low-concentration Photovoltaic Modules and Panels	UL Subject 8703 or UL 1703
QIBP	Photovoltaic Charge Controllers	UL 1741
FCJC	Photovoltaic Charge Controllers for Use in Hazardous Locations	UL 1741
QIKA	Photovoltaic Solar Trackers	UL Subject 3703
QIMS	Rack Mounting Systems and Clamping Devices for Flat-plate Photovoltaic Modules and Panels	UL Subject 2703
ZKLA	Photovoltaic Wire	UL Subject 4703
QIMV	Photovoltaic Lanterns – PV GAP Mark	
QIMY	Photovoltaic Modules and Panels – PV GAP Mark	IEC 61215, IEC 61646
IZMR	Fuseholders, Photovoltaic	UL Subject 4248-18
JFGA	Fuses for Photovoltaic Systems	UL Subject 2579
DIUR	Circuit Breakers, Molded Case and Circuit-breaker Enclosures for Use in Photovoltaic Systems	UL Subject 489B
QIDC	Photovoltaic DC Arc-fault Circuit Protection	UL Subject 1699B
WHXX	Switches, Dead-front for Use in Photovoltaic Systems	UL Subject 98B
WIBC	Switches, Enclosed for Use in Photovoltaic Systems	UL Subject 98B
WJBE	Switches, Molded Case, for Use in Photovoltaic Systems	UL Subject 489B
WHVA	Switches, Open Type for Use in Photovoltaic Systems	UL Subject 98A and UL Subject 98B
UZST	Thermal Solar - Solar Energy Systems Equipment	
UZUW	Solar collectors	UL Subject 1279
UZVY	Electrical solar controllers	UL Subject 1279
UZWT	Energy transfer units	UL Subject 1279
UZWW	Thermal storage units	UL Subject 1279
UZWZ	Solar water heaters	UL 174, UL 1453
IRGN	Fuel Cells and Hydrogen Generators	
IRGQ	Industrial trucks	UL 2267
IRGU	Handheld fuel cells	UL Subject 2265A or UL Subject 2265C
IRGZ	Stationary fuel cells	ANSI/CSA FC-1
NCBR	Hydrogen generators	UL Subject 2264B
FTCA	Engine Generators and Microturbines	
FTSR	Stationary Engine Generators	UL 2200
FTPU	Engine Generators fueled by biogas or raw natural gas	UL 2200
FTWG	Stationary Engine Generators for use in Hazardous Locations	UL 2200
FTCN	Portable Engine Generators	UL 2201
FTCZ	Engine Generators for use with Recreational Vehicles	UL 1248
EFVT	Special purpose tanks	UL 142, UL 2085, UL

		2080
FTVV	Engine control equipment	
FTWD	Engine controls	UL 508
FTWL	Ignition controls	UL 1012
JZGZ	Generator heads	UL 1004-1, UL 1004-4
IUXX	Fuel Gas Booster Compressor Equipment	UL 2200
ZGAA	Wind Turbine Generating Systems	
ZGEA	Large wind turbine generating systems	UL Subject 6140
ZGBP	Large wind turbine assemblies	UL Subject 6140
ZGEN	Small wind turbine generating systems	UL Subject 6140
ZGZJ	Wind turbine sub-assemblies	IEC 61400-1 or IEC 61400-2
ZGTA	Wind Turbine Tower Assemblies	UL Subject 6140
ZGDT	Wind Turbine Drive-train Systems and Equipment	UL Subject 6141
ZGCP	Safety-related control systems	UL Subject 6140
ZGFA	Inverters/converters	UL Subject 6141
ZGZN	Wind turbine tray cable	UL Subject 2277

APPENDIX B: ALTERNATE ENERGY CODES AND STANDARDS

Alternative energy equipment must be installed in accordance with model codes and installation standards. These codes require these products to be listed and labeled in accordance with applicable product standards.

UL standards are typically identified as Standards for Safety and cover reasonably foreseeable risks associated with a product. Limitations applicable to the products covered by the standard are delineated in the Scope section of the standard. UL standards are intended to:

- Identify requirements for evaluation of products and provide consistency in the application of these requirements.
- Provide guidance for development of products by manufacturers.
- Provide requirements compatible with nationally recognized installation codes

An UL Outline of Investigation is a document that contains the construction, performance, and marking criteria used by UL to investigate a product when the product is not covered by the scope of an existing UL Standard for Safety. Outlines are not consensus documents and do not require review by an UL Standards Technical Panel (STP) or other external group.

CEI 82-25	Guide for Design and Installation of Photovoltaic (PV) Systems Connected to MV and LV Networks
CSA FC-1	Standard for Stationary Fuel Cell Power Systems
EN 61215	Crystalline silicon terrestrial photovoltaic modules - Design qualification and type approval
EN 61646	Thin-film terrestrial photovoltaic modules - Design qualification and approval
EN 61730-1	Photovoltaic (PV) Module Safety Qualification - Part 1: Requirements for Construction
EN 61730-2	Photovoltaic (PV) Module Safety Qualification - Part 2: Requirements for Testing
IBC	International Building Code
ICC 700	National Green Building Standard
IFC	International Fire Code
IFGC	International Fuel Gas Code
IGCC	International Green Construction Code
IMC	International Mechanical Code
IEC 61215	Crystalline silicon terrestrial photovoltaic modules - Design qualification and type approval
IEC 61646	Thin-film terrestrial photovoltaic modules - Design qualification and approval
IEC 61730-1	Photovoltaic (PV) Module Safety Qualification - Part 1: Requirements for Construction
IEC 61730-2	Photovoltaic (PV) Module Safety Qualification - Part 2: Requirements for Testing
IEC 62108	Concentrator Photovoltaic (CPV) Modules and Assemblies - Design Qualification and Type Approval
IEEE 1262	IEEE Recommended practice for qualification of photovoltaic (PV) modules

IEEE 1547	IEEE Standard for Interconnecting Distributed Resources with Electric Power Systems
NEC (NFPA 70)	National Electrical Code
NFGC (NFPA 54)	National Fuel Gas Code
NFPA 1 (UFC)	Uniform Fire Code
NFPA 37	Standard for the Installation and Use of Stationary Combustion Engines and Gas Turbines
NFPA 54 (NFGC)	National Fuel Gas Code
NFPA 70 (NEC)	National Electrical Code
NFPA 99	Standard for Health Care Facilities
NFPA 110	Standard for Emergency and Standby Power Systems
NFPA 853	Standard for the Installation of Stationary Fuel Cell Power Plants
UL 98A	Outline of Investigation for Open-Type Switches
UL Subject 98B	Outline for Enclosed and Dead-Front Switches for Use in Photovoltaic Systems
UL 458	Standard for Safety of Power Converters/Inverters and Power Converter/Inverter Systems for Land Vehicles and Marine Crafts
UL Subject 458A	Outline of Investigation for Power Converters/Inverters for Electric Land Vehicles
UL Subject 489B	Outline for Molded-Case Circuit Breakers, Molded-Case Switches, and Circuit-Breaker Enclosures For Use With Photovoltaic (PV) Systems
UL Subject 508I	Outline for Manual Disconnect Switches Intended for Use in Photovoltaic Systems
UL 790	Standard Test Methods for Fire Tests of Roof Coverings
UL 997	Standard Test Methods for Wind Resistance of Prepared Roof Covering Materials
UL 1004-1	Rotating Electrical Machines - General Requirements
UL 1004-4	Electric Generators
UL 1248	Standard for Safety of Engine-Generator Assemblies for Use in Recreational Vehicles
UL Subject 1279	Outline of Investigation for Solar Collectors
UL Subject 1699B	Outline of Investigation for Photovoltaic (PV) DC Arc-Fault Circuit Protection
UL 1703	Standard for Safety of Flat-Plate Photovoltaic Modules and Panels
UL 1741	Standard for Safety of Inverters, Converters and Controllers for Use in Independent Power Systems
UL Subject 1973	Outline of Investigation for Batteries for Use in Light Electric Rail (LER) Applications and Stationary Applications
UL 2200	Standard for Stationary Engine Generator Assemblies
UL 2201	Standard for Safety of Portable Engine-Generator Assemblies
UL Subject 2262	Outline of Investigation for Portable Proton Exchange Membrane (PEM) Type Fuel Cell Power Plants With or Without Uninterruptible Power Supply (UPS) Features and Portable Proton Exchange Membrane (PEM) Type Fuel Cell Modules for Factory Installation in Original Equipment Manufacturer (OEM) Type Equipment, for Indoor Use
UL Subject 2264B	Outline of Investigation for Hydrogen Generators Using Water

	Reaction
UL Subject 2265A	Outline of Investigation for Hand-held or Hand-Transportable Fuel Cell Power Units with Disposable Methanol Fuel Cartridges for use in Original Equipment Manufacturer's Information Technology Equipment
UL Subject 2265C	Outline of Investigation for Hand-Held or Hand-Transportable Alkaline (Direct Borohydride) Fuel Cell Power Units And Borohydride Fuel Cartridges For Use With Consumer Electronics or Information Technology Equipment.
UL 2267	Standard for Fuel Cell Power Systems for Installation in Industrial Electric Trucks
UL Subject 2277	Outline of Investigation for Flexible Motor Supply Cable and Wind Turbine Tray Cable
UL Subject 2579	Outline for Low-Voltage Fuses - Fuses for Photovoltaic Systems
UL Subject 2703	Outline for Rack Mounting Systems and Clamping Devices for Flat-Plate Photovoltaic Modules and Panels
UL Subject 2736	Outline for Single Pole Separable Interconnecting Cable Connectors for Use with Wind Turbine Generating Systems
UL Subject 3703	Outline of Investigation for Solar Trackers
UL Subject 3730	Outline for Photovoltaic Junction Boxes
UL Subject 4248-18	Outline for Fuseholders - Part 18: Photovoltaic
UL Subject 4703	Outline of Investigation for Photovoltaic Wire
UL Subject 5703	Outline for Determination of the Maximum Operating Temperature Rating of Photovoltaic (PV) Backsheet Materials
UL Subject 6140	Outline of Investigation for Wind Turbine Generating Systems
UL Subject 6141	Outline of Investigation for Wind Turbine Converters and Interconnection Systems Equipment
UL Subject 6142	
UL Subject 6703	Outline for Connectors for Use in Photovoltaic Systems
UL Subject 6703A	Outline for Multi-Pole Connectors for Use in Photovoltaic Systems
UL Subject 8703	Outline of Investigation for Concentrator Photovoltaic Modules and Assemblies
UL Subject 9703	Outline for Distributed Generation Wiring Harnesses
UMC	Uniform Mechanical Code
USEC	Uniform Solar Energy Code